

Optimizing Fracturing Through Perforation

CoFrac™ Perforating System -
Integrating propellant and shaped
charges to deliver maximum energy
to remove compaction and improve
reservoir permeability.

*Authors: Larry Albert, Nadir Nery, Hema Prapoo,
Allied-Horizontal Wireline Services;*

*Dennis Kwok, Grace Jiang, ARECO Technology; Peng Dai,
Bo Qu, Ruitong Enetech International*



alliedhorizontal.com

CoFrac™ Perforating System is designed to optimize fracturing operations. The integration of propellant and shaped charge explosives provides one ignition and two explosions. Propellants deflagrate within perforation tunnels and release energy directly to the formation, breaking through the crush zone and eliminating near well-bore damage. A safe, simple process requiring no extra equipment, tools, or personnel, CoFrac Perforating lowers fracture treating pressures, improves sand placement and increases well production while extending the working life of a well.

Table of Contents

The Problem - Compaction and Reduced Permeability	2
Horizontal is the New Normal	3
Solid Propellant Works	4
A Quick Review of Jet Perforating.....	5
Composite Charge is the Key	6
CoFrac Perforating Process	7
Propellant Deflagrates in Perforation Tunnel.....	8
Perforation Tunnel Pressure Test.....	10
Surface Testing of Composite Charge	11
API Target Testing of Composite Charge	13
Proven Field Results	
New Wells Performance Evaluation.....	14
Well Refrac Performance Evaluation	15
Extended Test over 34 months	16
Eagle Ford Horizontal Completion.....	17

The Problem - Compaction and Reduced Permeability

Our industry has worked to solve tunnel compaction and improve permeability for decades. Conventional perforating provides one ignition, one explosion. A standard shaped charge constructed of high energy explosives burns very fast when detonated and produces a high-speed jet penetrating the gun body, casing, cement annulus and tunneling into the formation to create perforation. This jet shockwave of high pressure, temperature and speed creates a crushed zone around the perforating tunnel that can plug the end, blocking communication between wellbore and formation. When severe, permeability is significantly reduced and limits reservoir productivity. These methods have been in use more than 80 years and the tunnel compaction problem has not been adequately resolved.

Several Solutions have been developed to attempt to solve the problem. These include:

- Underbalanced Perforating
- Overbalanced Perforating
- Dynamic Underbalanced Perforating
- Solid Propellant (sticks of propellant post-perforating)
- Composite Perforating (combination of solid propellant and perforating)
- Over Gun Body Solid Propellant Sleeves
- Internal Gun Body Solid Propellant Discs

These solutions were designed primarily for vertical wells, not for horizontal plug and perf operations.

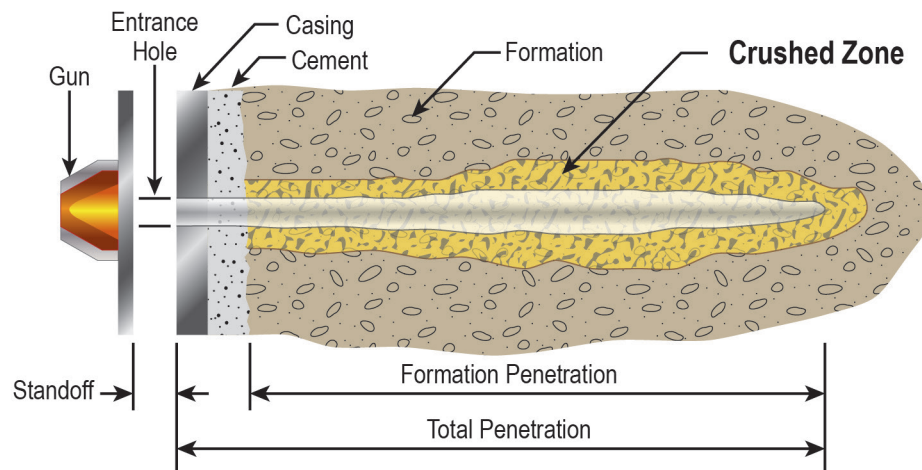

Horizontal is the New Normal

Over the past decade, the USA onshore market has transitioned rapidly from vertical to horizontal drilling as energy and production companies began to target unconventional reservoirs. These unconventional reservoirs are generally low porosity and ultra-low permeability (shales, tight shaly sands, etc.) and are not commercially productive without hydraulic fracturing. A typical horizontal well has casing cemented and is completed in stages (sections of the well), from the bottom (toe) to the top of lateral (heel). Prior to fracturing, plugs are set and stages are perforated. The plug & perforating assembly is pumped-down through the lateral to target depth. This type of perforation operation limits gun selection to slick hollow steel carriers with stages perforated in an over-balanced condition.

There are challenges to horizontal completions. Ideally, each perforation in the stage should take the same amount of fluid and proppant; therefore, assuring an optimal completion with 100% of the reservoir along the lateral adequately fractured and propped. To accomplish this, a number of techniques are utilized, including limited entry, diverters, shaped charge selection, etc. Perforation shaped charge selection is important and there are a number of options available depending upon the application and objective. These include Big Hole, Deep Penetrating, Super Deep Penetrating, Good Hole and Equal Hole. Over the past few years, there is a general trend towards the utilization of Equal Hole charges. These charges are designed to provide equal entry hole diameter perforations around the casing circumference regardless of gun stand-off. Keeping perforation surface area constant helps facilitate equal fluid and proppant distribution per perforation. *Despite best efforts, it can be difficult to ensure all perforations have been properly stimulated.* If perforations do not breakdown and take fluid, this will impact stimulation efficiency (as seen in figure below). Poor perforation performance can create tortuosity, leading to higher break-down pressures and limited proppant entry. In the worst case, zones cannot be stimulated without exceeding casing pressure limits, or the frac job will screen off while pumping proppant.

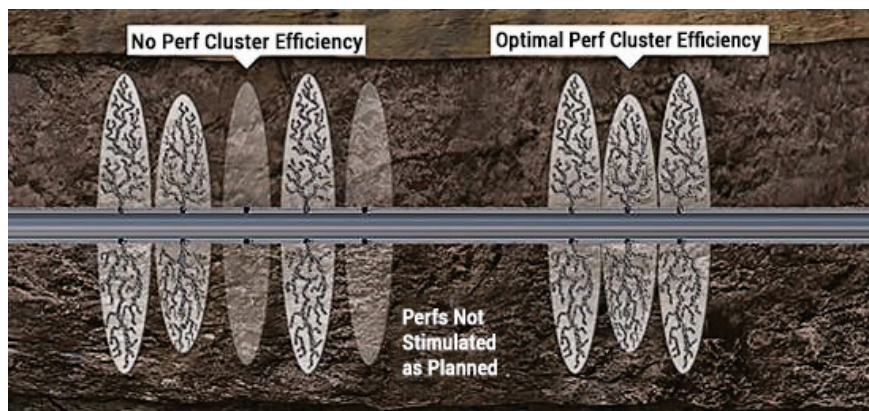

Solid Propellant Works

Solid propellant has proven to be an effective method to break-up tunnel compaction and improve reservoir permeability.

Pressure build up is the key:

- Perforating with high energy explosives releases energy very quickly (microseconds) crushing the formation
- Solid propellant releases energy 1000 times slower (milliseconds), the pressure pulse fractures compacted zone and formation
- Hydraulic fracturing releases energy over seconds / minutes creating fractures in the formation

Perforating

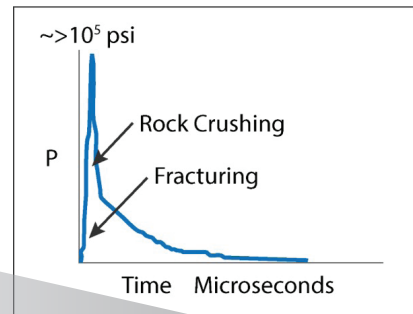

Pressure vs. Time for Typical Explosive Event

Propellant

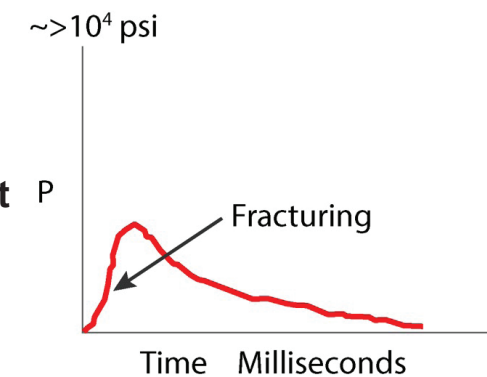

Pressure vs. Time for Typical Propellant Event

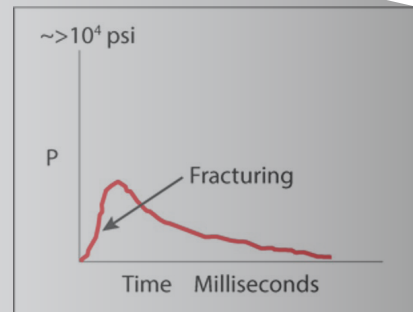

Pressure vs. Time for Typical Propellant Event

Hydraulic Fracturing

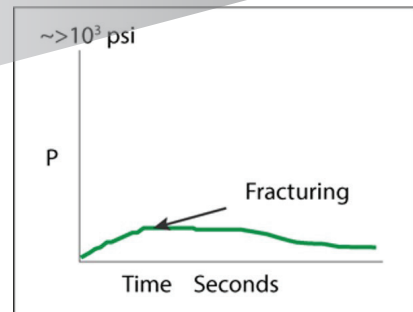

Pressure vs. Time for Hydraulic Fracturing

A Quick Review of Jet Perforating

A shaped charge includes a cylinder of high explosive (RDX, HMX, HNX, PYX) with a hollow cavity lined with a thin layer of metal and a detonator on the opposite end.

The shape of the cavity, liner material (heavy metals), quantity of explosive, type of explosive and case are the primary factors affecting the high velocity jet that creates the perforation.

Stand-off to target is required for jet to achieve maximum velocity.

Perforating jet tip velocity can be as high as 30,000 fps and delivers as much as 1.5 million psi to the face of the formation. This high speed, high energy jet penetrates the gun carrier, casing, cement and formation, punching a tunnel through the rock collapsing large pores along the tunnel creating a crushed zone. The trailing side of the jet (Umbrella Tail) is moving slower (~ 3,000 fps). The CoFrac design takes advantage of this Umbrella Tail to deliver the solid propellant to the perforation tunnel where it can deflagrate.

Shaped Charge Components

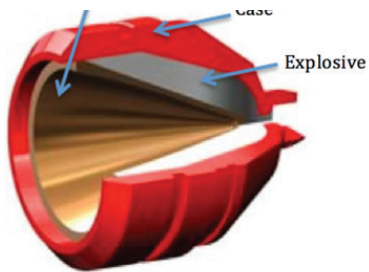

High Speed Image - Detonation & Jet Formation

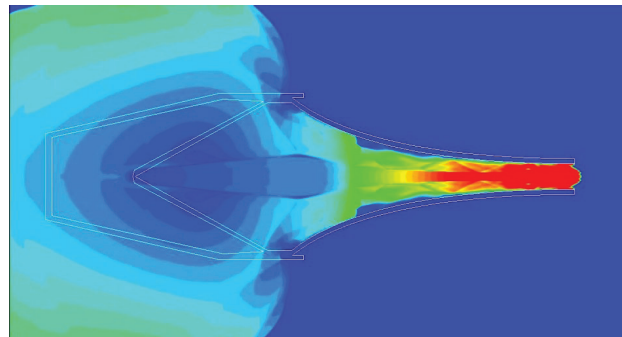

Stand-Off

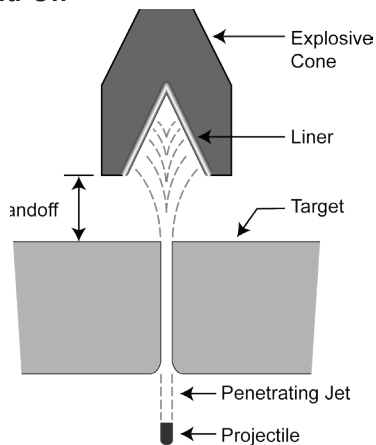

Perforating Jet Velocities

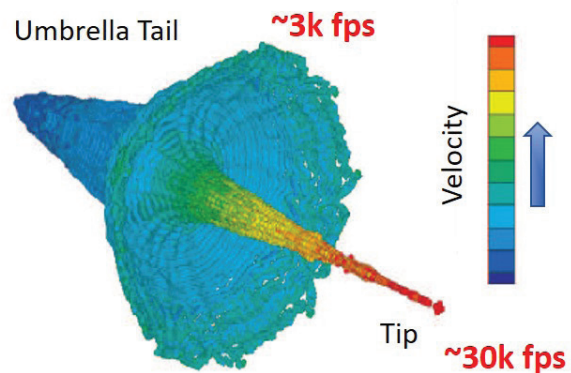

Composite Charge is the Key

A composite solid propellant cap for the perforating shaped charge is the key to deflagration in the perforation tunnel.

The propellant cap, with concentric hole (aligned with center of shaped charge liner) and solid propellant molded at angles, was designed to allow optimum jet performance while distributing propellant material into the perforation tunnel before it deflagrates. The cap is shaped to fit the front of most 3-1/8 shaped charges, regardless of type (BH, DP, SDP, GH or EH) and can be loaded in gun carriers of multiple lengths and shot density.

The composite perforating charge consists of...



CoFrac Perforating Process

1. The shaped charge detonates and initiates the perforation.
2. As the perforation jet is formed super high pressure (more than 145,000 psi) is produced within the gun body.

3. Under this super high pressure propellant won't explode.
4. As the jet is formed, pressure in the perforation tunnel is low compared to pressure inside the gun body.



5. The propellant material in the case on the shaped charge face is pushed into the perforation tunnel following the jet.
6. The propellant deflagrates within the formation as the jet energy extends the tunnel.



7. The deflagration of the propellant releases energy directly to the formation, generating multiple fractures and breaking through the tunnel compacted zone.



Propellant Deflagrates in Perforation Tunnel

A key objective for the composite charge was the deflagration of the propellant inside the perforation tunnel. To prove this concept a test was setup with a high speed camera (50,000 frames per second) to capture the deflagration process.

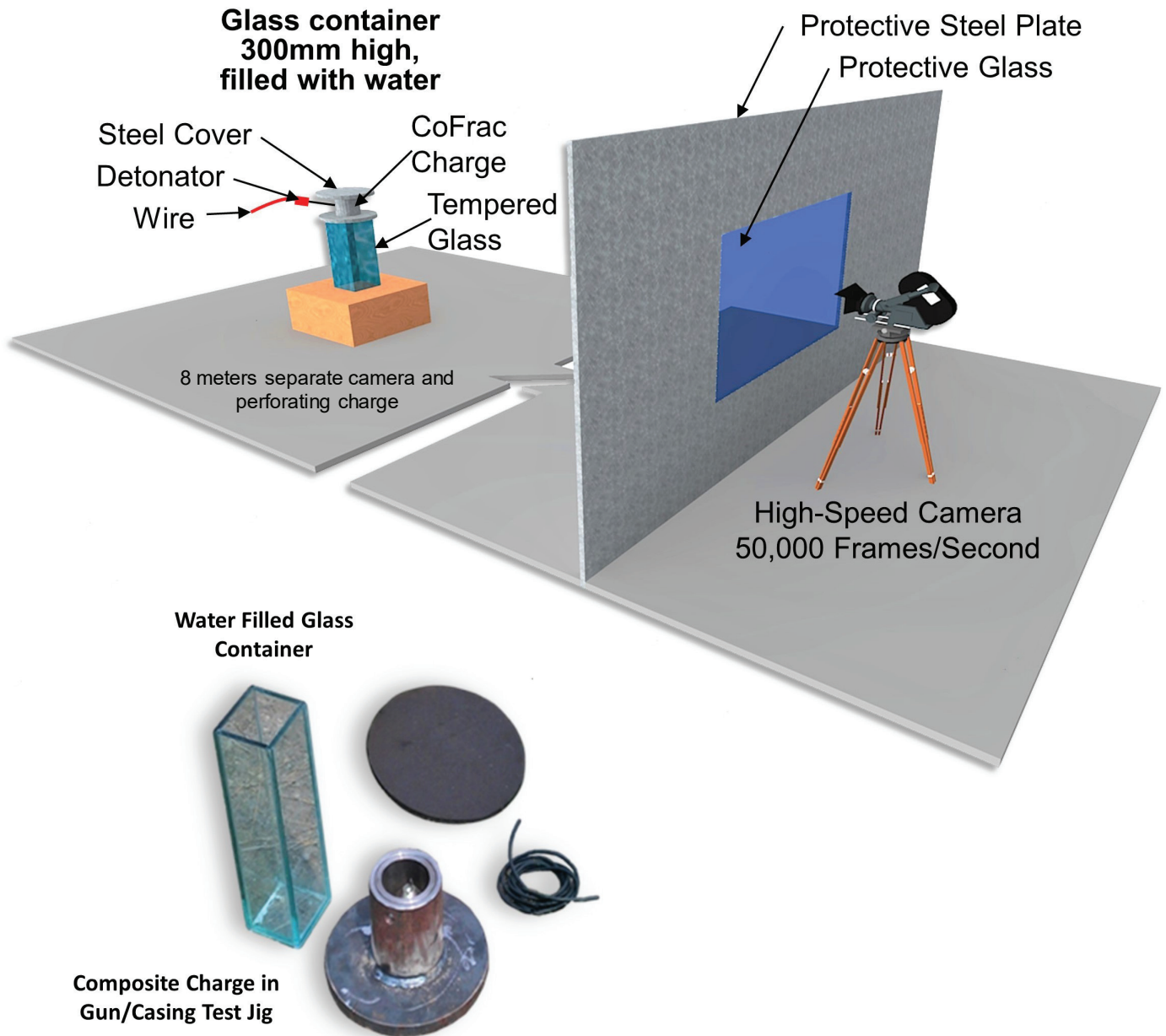

A high speed camera (50,000 frames per second) was used to capture the deflagration process in a test jig.

Captured by High Speed Camera

- High-speed camera captured images of perforation and propellant deflagration in 3 milli-seconds real time.
- High-speed photos indicate the propellant deflagrated inside target and within tunnel.

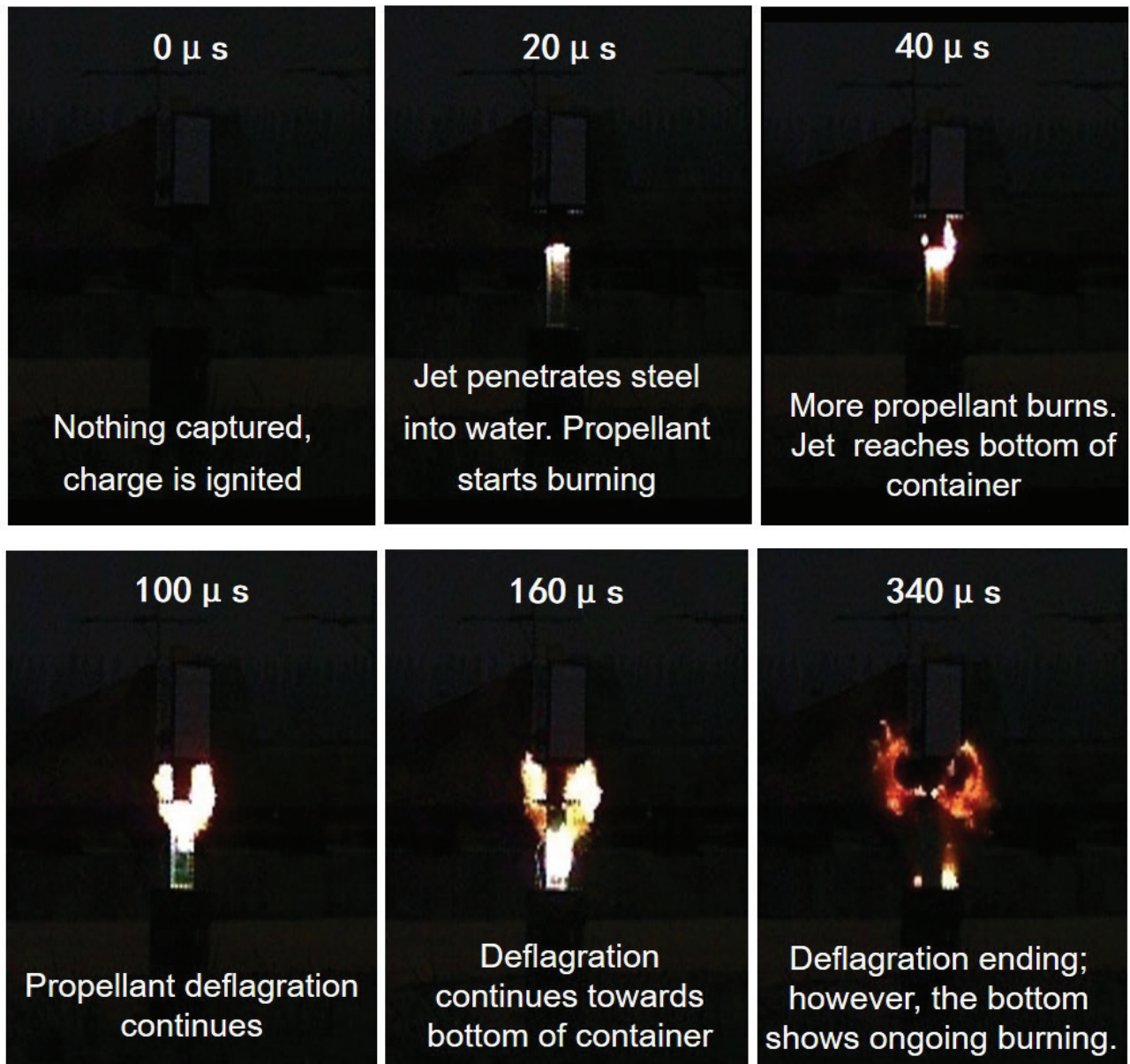

Perforation Tunnel Pressure Test

A test chamber was setup to measure the perforation tunnel pressures during the perforating event. The pressure parameters were observed on the p-t curve for the Composite Charge.

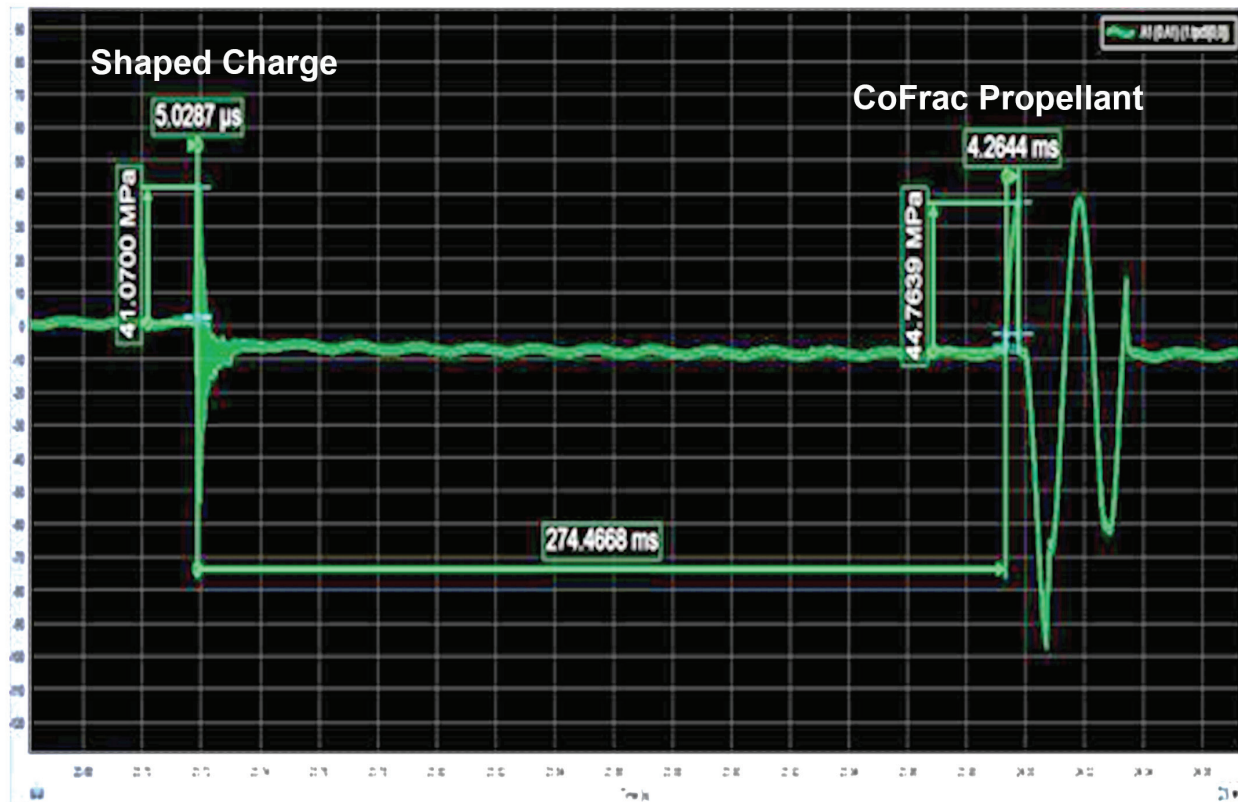

- The CoFrac propellant pressure wave appeared 274.47ms after the Shaped Charge pressure wave
- The Max. Pressure generated by Shaped Charge is 41.07MPa (5,956.70psi) with a duration of 5.03μs
- The Max. Pressure generated by CoFrac propellant is 44.76MPa (6,491.89psi) with a duration of 4.26ms (850 times longer than shaped charge)

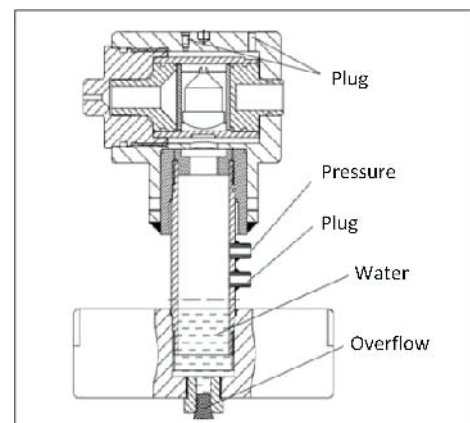

Surface Testing of Composite Charge

A test was conducted to compare a conventional shaped charge and the composite charge in different material targets.

- Experiment objective: Compare perforation hole size and target fracturing for composite charge and conventional perforator in a simulated, confined (stressed) space in steel and sandstone targets
- Shaped charge same for both tests
- Environmental Conditions: Room temperature, standard atmospheric pressure

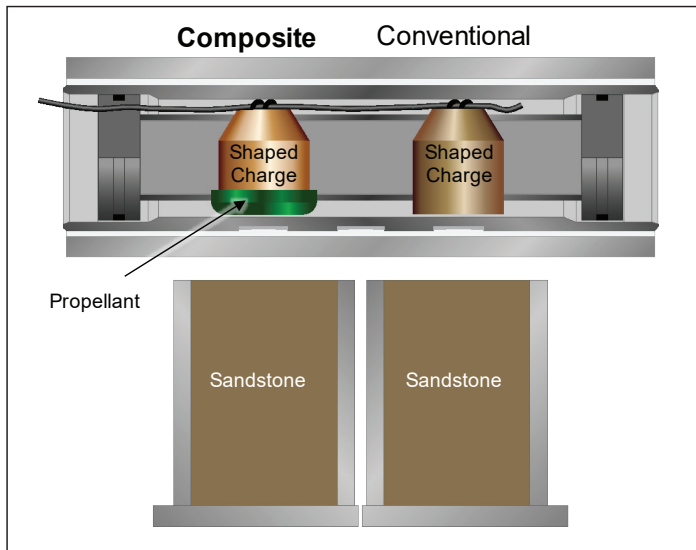

Design of testing device



Sandstone targets

Surface Testing of Composite Charge

Test results show composite charge enlarged the perforation tunnel and fractured the sandstone target.

Conventional Shaped Charge



Composite Perforating System

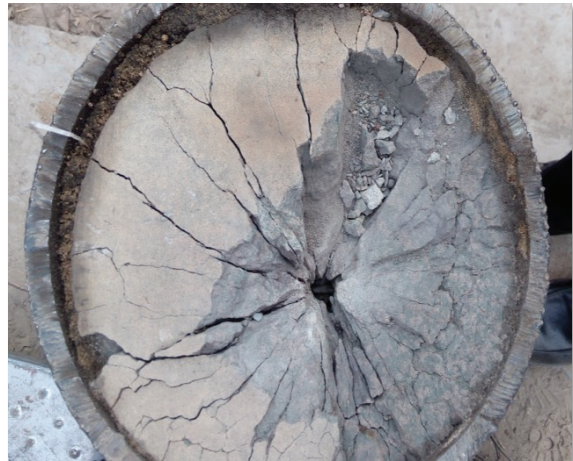

Aluminum Molds of CoFrac Perforations



API Target Testing of Composite Charge

The Composite and Conventional gun systems were perforated in API concrete targets. The same shaped charge was used in both gun systems.

Concrete Test Targets: 17.1 ft X 4.6 ft



Conventional Shaped Charge



Composite Shaped Charge



CoFrac Fracture

Proven Field Results

Deployed in over 2,000 wells in Chinese reservoirs with very low natural permeability, similar to USA unconventional reservoirs.

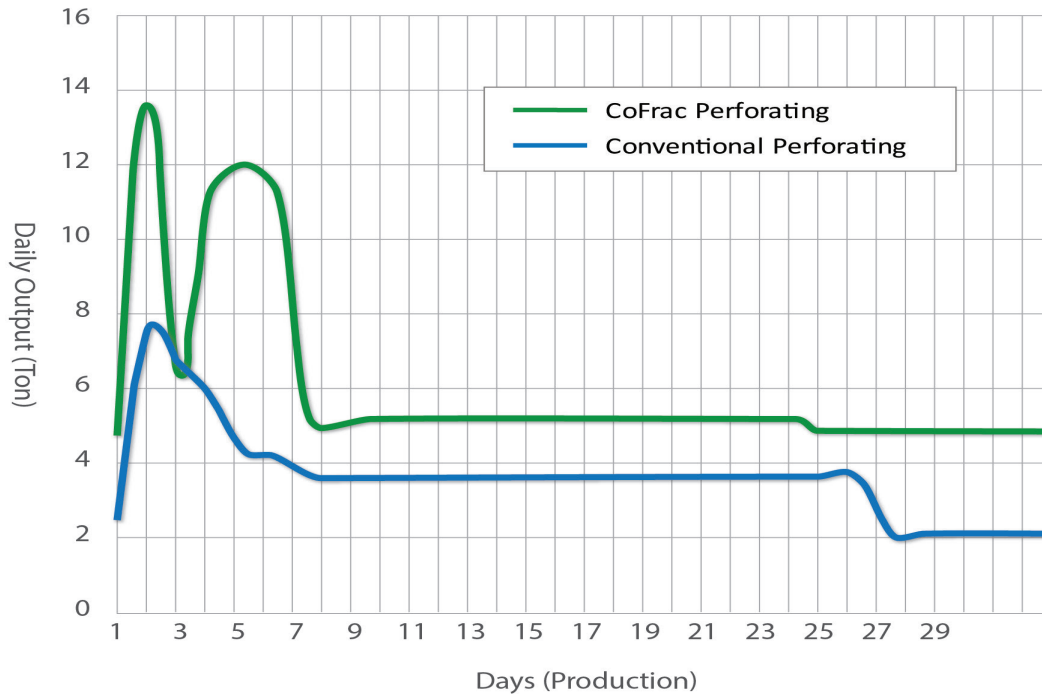

7 New Wells Performance Evaluation

4 wells – Composite Perforating System

3 wells – Conventional Perforating

* Fracturing equipment and procedures same for both groups.

Results:

Composite perforation system had higher initial production. Avg. 65.7 bbls/day for first 7 days.
Conventional 35 bbls/day avg. over 7 days.

Composite 30.7 bbls/day higher, 88% increase

Composite perforating system had slower decline rate. Day 8 to 25 avg. 36.4 bbls/day.
Conventional only 25.7 bbls/day.

Composite 10.7 bbls/day higher, 42% increase

After day 25, avg. Composite 35/day; Conventional 15 bbls/day.

Composite 20 bbls/day higher, 133% increase

Proven Field Results

Deployed in over 2,000 wells in Chinese reservoirs with very low natural permeability, similar to USA unconventional reservoirs.

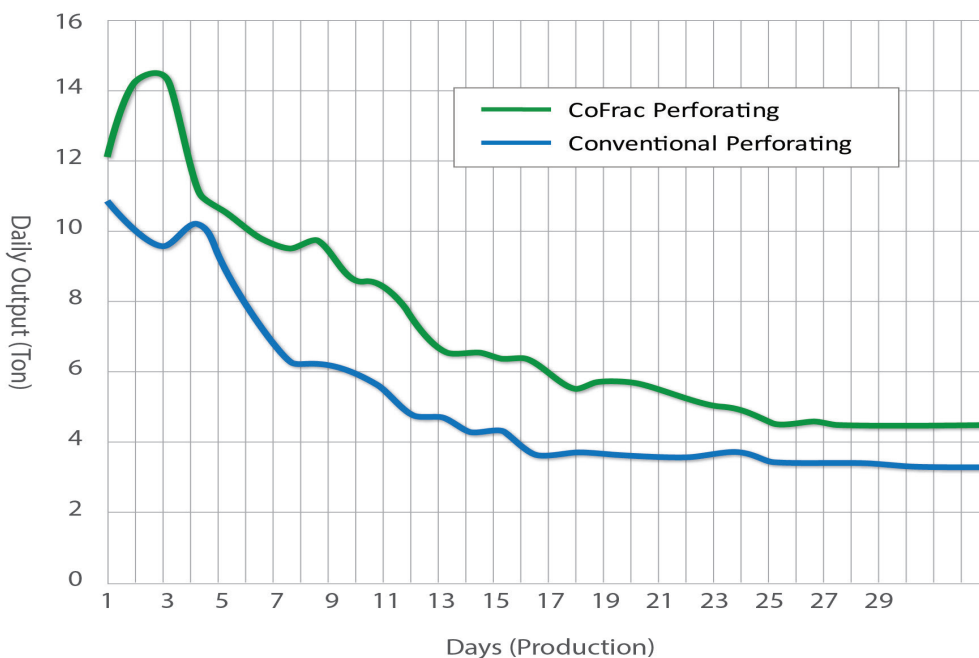

12 Well Refrac Performance Evaluation

7 wells – Composite Perforating System

5 wells - Conventional Perforating

* Fracturing equipment and procedures same for both groups.

Results:

Composite perforating system had higher initial production. Avg. 23 bbls/day for first 7 days.

Conventional avg. 16.8 bbls/day over 7 days.

Composite 6.2 bbls/day higher, 37% increase

Composite perforating system had slower decline rate. Day 8 to 25 avg. 9.6 bbls/day.

Conventional 7.5 bbls/day.

Composite 2.1 bbls/day higher, 28% increase

After day 25, avg. Composite 8.9 bbls/day, Conventional 6.1 bbls/day.

Composite 2.8 bbls/day higher, > 46% increase

Proven Field Results

Deployed in over 2,000 wells in Chinese reservoirs with very low natural permeability, similar to USA unconventional reservoirs.

Extended Test over 34 months

From 2009 to 2012, Ganguyi Oilfield selected 6 wells in same formation and area and conducted a comparison test.

Under same well conditions, oil production was monitored for 34 months for 3 wells completed with Composite perforator and 3 wells with Conventional perforator.

Composite perforating system wells had higher initial oil production and slower decline rates. For 34 months period total production was 31,191 bbls for Composite wells, and 9,424 bbls for Conventional wells, an increase of 21,767 bbls (+231%).

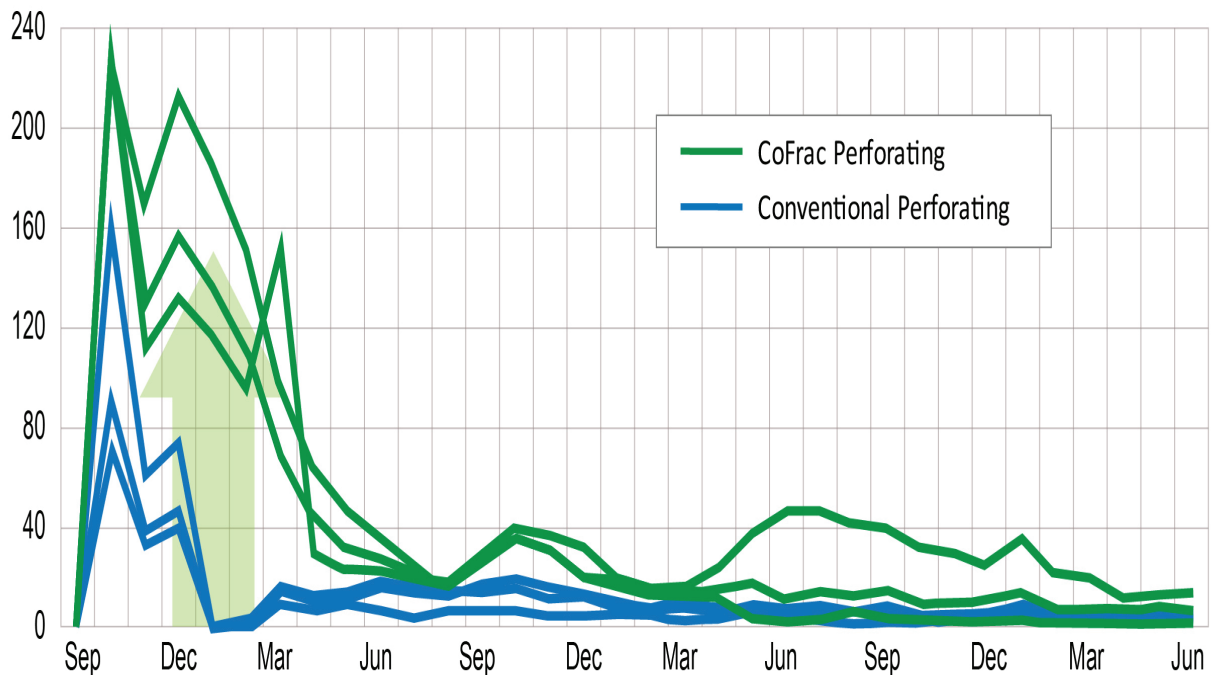

Proven Field Results

The initial field trials have started in the USA onshore market.

Eagle Ford Horizontal Completion

The initial trial Eagle Ford well in South Texas. The well had a 5,000 ft. lateral completed in 25 stages (1 toe stage and 24 pump-down plug & perf). The well had 15% HCl acid spotted on the perforations before breakdown. Each stage was stimulated with slickwater and 50,000 lbs. of sand at 90 bpm. The stages were perforated with composite and conventional guns alternated every 3 stages (Equal Hole Shaped Charge).

- Pressures will vary along the lateral based on formation heterogeneity
- Composite perforating system will microfracture formation and improve connectivity of reservoir to the wellbore (lower skin)
- For this test evidence for reduced skin will show in reduction in pressure difference between breakdown and treating.
- There are 7 stages with Delta Pressure > 2350 psi and 6 of 7 of those are with conventional guns
- Average delta pressure was reduced 15% on the composite perforation stages

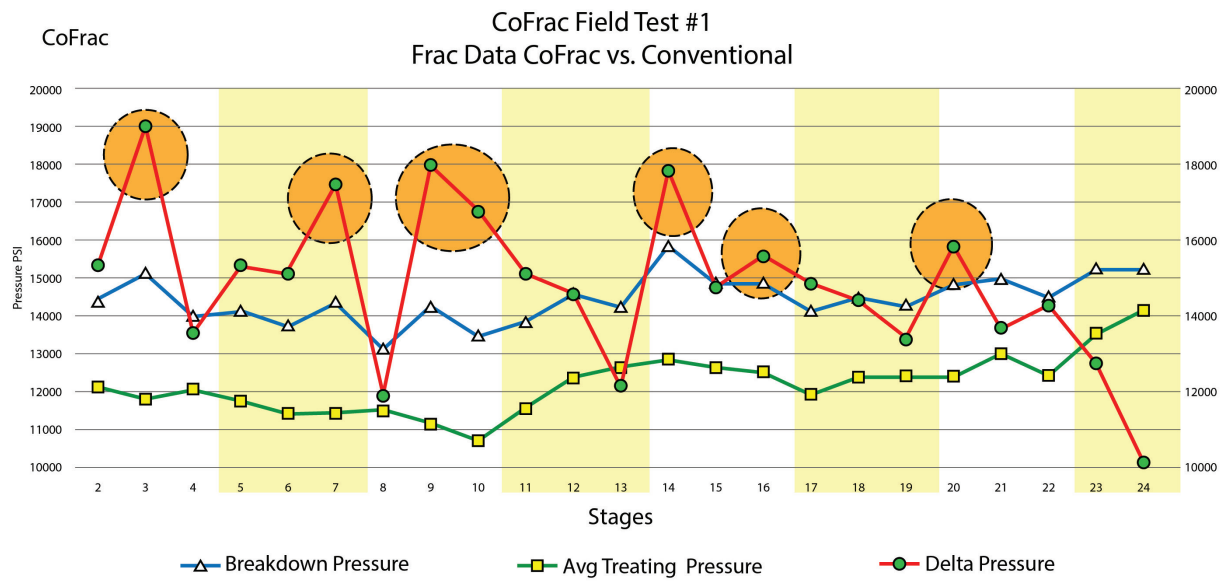

USA Field Test #2: Eagle Ford Horizontal Completions – 3 Well Pad

This was a 3 horizontal well pad in the Eagle Ford in South Texas. The test included CoFrac and Conventional perforating, with and without acid during break-down.

Perforation Design

Well No.	No. Stages	CoFrac	Acid	CoFrac + Acid	CoFrac No Acid	Conv No Acid
1H	17	14	8	8	6	3
2H	15	12	6	6	6	3
3H	17	14	7	7	7	3
Total	49	40	21	21	19	9

A total of 49 stages, CoFrac on 40 stages. Of these 40, 19 stages were without acid, 21 stages with acid. 9 stages were conventional perforating, all conventional stages were without acid.

The lowest breakdown pressure was on the CoFrac with no acid stages. Overall treating pressures were lower with CoFrac versus conventional perforating.

The lowest treating pressures were on stages perforated with CoFrac with acid pumped.

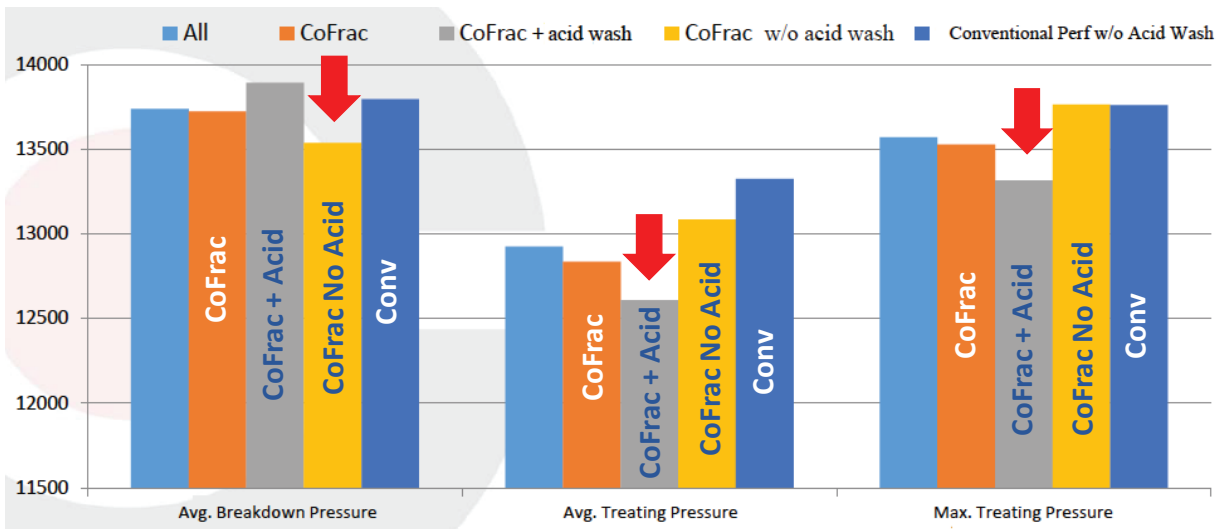

USA Field Test #3: Eagle Ford Horizontal Completions – 5 Well Pad

This was a 5 horizontal well pad in the Eagle Ford in South Texas. The test included CoFrac and Conventional perforating, with and without acid during break-down.

Perforation Design

Well No.	No. Stages	Perforation Method & Treatment					Conv + Acid
		CoFrac	Conv	CoFrac No Acid	CoFrac + Acid	Conv No Acid	
1H	34	19	15	16	3	11	4
2H	31	28	3	25	3	2	1
3H	33	0	33	0	0	29	4
4H	34	33	1	31	2	0	1
5H	22	12	10	10	2	8	2
Total	154	92	62	82	10	50	12

A total of 154 stages, CoFrac on 92 stages. Of these 92, 82 stages were without acid, 10 stages with acid. 62 stages were conventional perforating, 50 conventional stages were without acid, 12 stages with acid. Completed a Stepdown test on 4 stages in 2H well.

Breakdown pressures were lower on stages without acid. Treating pressures were lower with CoFrac versus Conventional. The lowest treating pressures were on stages perforated with CoFrac with acid pumped.

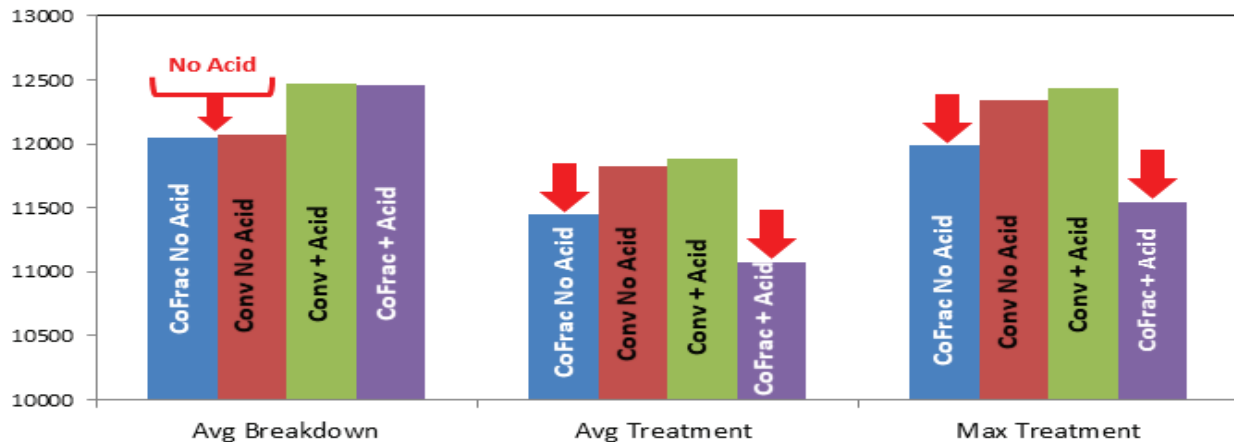

**Built on the commitment of industry
leading safety and customer
satisfaction, we are dedicated
to provide you the highest value
wireline services.**

Contact Your local
Allied-Horizontal Representative
or Visit Us Online at:

alliedhorizontal.com

