

Delivers accurate compensated bulk density and lithology measurements

Applications

- Determining formation porosity and lithology
- Logging through drillpipe past severe hole conditions
- Determining fluid density (in combination with other measurements)
- Identifying formation gas
- Identifying mineral properties
- Providing input to advanced formation-evaluation programs
- Providing input to determine mechanical properties of rock
- Providing input to seismic programs
- Providing detailed well-to-well correlation
- Delineating the reservoir

Features and Benefits

- The tool uses an articulated shoe that reduces the effects of borehole size and rugosity and provides a high-quality measurement.
- The small diameter of the tool facilitates deployment in wireline or memory mode to mitigate the risk of bridging events and to reduce nonproductive time.

Tool Description

The Compact Photodensity (MPD) tool provides bulk density, caliper, and photoelectric (P_e) measurements that determine porosity and lithology in conventional and slim wells. The unique profile of the tool enables it to pass through as small as 2.5 in. (5.7 mm).

The density and P_e detectors are contained in an articulated shoe, which maintains close contact with the formation over caved intervals. The shoe eliminates the gross errors typical of mandrel tools in similar conditions and has smaller borehole-size corrections than many conventional tools.

A connector at the bottom of the tool can be rotated 180° to provide 0.5 in. (13 mm) of standoff to tools below. When combined with the Compact Sonic Sonde (MSS) and Compact Array Induction (MAI) tools, the MPD tool can obtain high-quality sonic and induction data and eliminates the need for an intersonde crank.

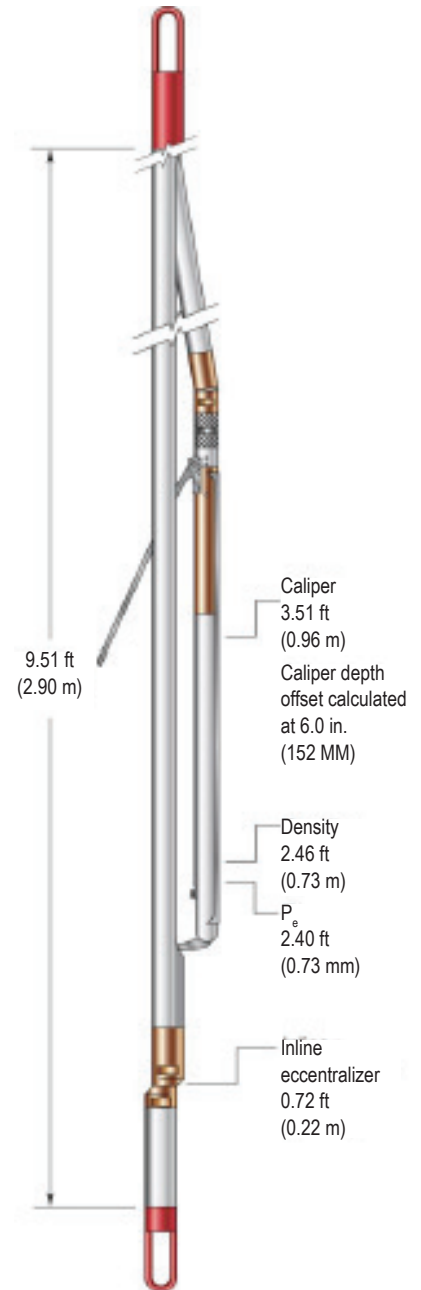

The Compact photodensity (MPD) tool can operate in memory or surface-readout mode.

Measurement

Data	Density, P _e caliper
Logging Speed	Standard: 1,800 ft/hr (550 m/hr) High Speed: 3,600 ft/hr (1,097 m/hr) in PED mode High Resolution: 1,800 ft/hr (550 m/hr) in PED mode
Measurement range	Density: 1.0 to 3.0 gm/cm ³ (1,000 to 3,000 kg/m ³)
Measurement Accuracy	Density: ±0.01 gm/cm ³ P _e : ±0.2 B/e
Vertical resolution	Standard mode: 14.6 in. (371 mm) VECTAR mode: 5.9 in. (150 mm) P _e : 8.0 in. (200 mm)
Depth of investigation	3.9 in. (100 mm) at 2.3 gm/cm ³
Borehole fluids	WBB, OBM, Air

Specifications

Maximum outer diameter	2.25 in. (57 mm) with 4 in. wear plate 2.45 in. (62 mm) with 8 in. wear plate
Length	9.51 ft (2.90 m)
Weight (air)	90.0 lb (41 kg)
Maximum temperature	320° F (160° C)
Maximum pressure	15,000 psi (103 MPa)
Maximum borehole diameter	18 in. (457.2 mm)
Minimum borehole diameter	2.8 in. (70 mm)



wirelinelogs.com

Compact™ is the property of Weatherford and may be registered in the United States and/or other countries, and may be protected by one or more U.S. and/or foreign patents.